

Pump group is a device that ensures and regulates the circulation of the solar fluid between the solar collectors and the tank. The group consists of a circulating pump as well as control and measuring devices. It can be used both for flat solar collectors and for vacuum collectors. The advantage of the double pump group is that it enables controlling the temperature of the solar system heating medium supply and the return.

Parameter	Value
Dimensions	480x330x170
Max. pressure	6 bar
Flow range	8-28 L/MIN
Pressure gauge scale	0-10 bar
Thermometer scale	0-120 °C
Pump type	Grundfos UPM3 Solar 25-145
Pump installation length	130 mm.
Body material	Brass, Powder-coated steel
Insulation material	EPP
Sealing components	EPDM
Medium	Solar fluid only (non-toxic glycol-water mixture with corrosion inhibitors)

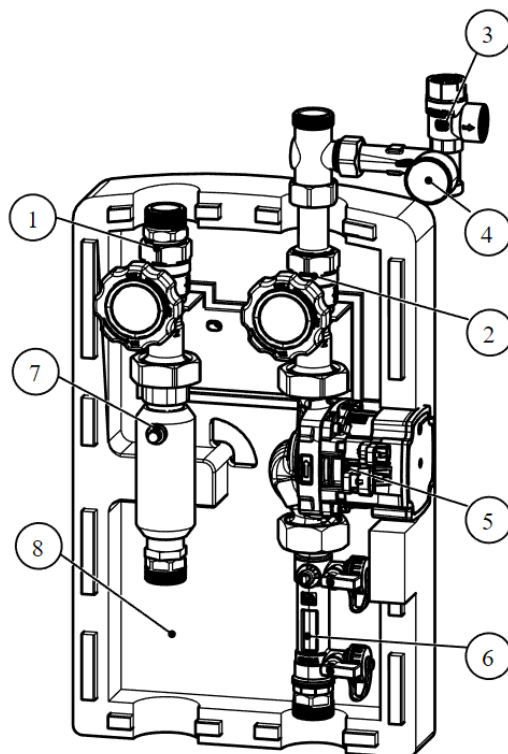

1. BALL VALVE WITH HIGH PARAMETER THERMOMETER
2. BALL VALVE WITH LOW PARAMETER THERMOMETER
3. 6 BAR PRESSURE RELIEF VALVE
4. GROUP WITH A PRESSURE GAUGE FITTED WITH AN EXPANSION VESSEL PORT
5. GRUNDFOS UPM3 SOLAR 25-145 CIRCULATING PUMP
6. ROTAMETER WITH SOLAR SYSTEM FILLING AND EMPTYING VALVES
7. AIR SEPARATOR WITH AIR VENT
8. INSULATION OF THE PUMP GROUP